

SP-20E

Automatic Case Former

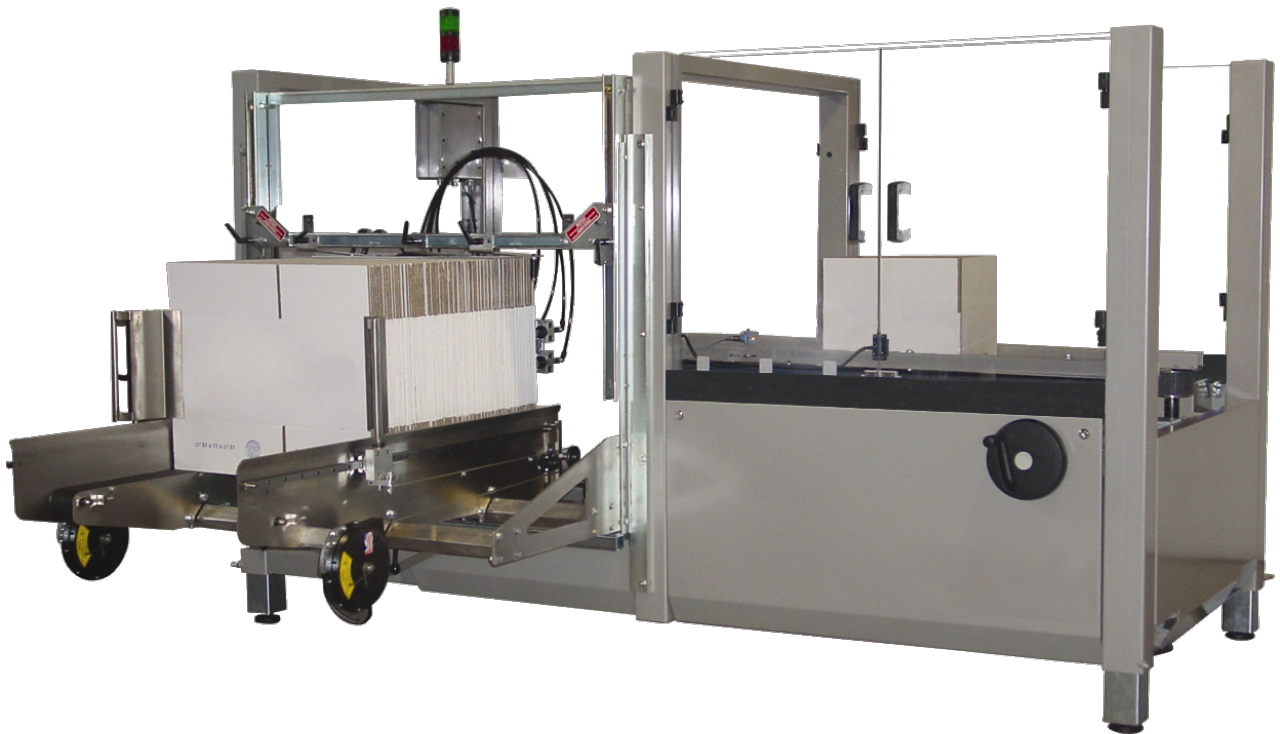

The SP-20E Automatic Case Former is a high performance case erector that has the ability to erect and seal cases with tape at speeds up to 20 cases per minute. The design of the SP-20E Case Former focuses on innovation and ease-of use, providing customers with up-time reliability.

SP-20E

Automatic Case Former

Features:

- Automatic operation
- Easy load powered case magazine
- Allen - Bradley components
- Heavy duty welded frame
- Case detection sensor
- Low tape alarm
- Low case alarm
- Power flap closer

Technical Features:

Speed:	Up to 20 cases/min.
Operator interface:	Touchscreen display
Tape applicator:	2" tape head
Electric:	110 V, 1 phase, 60 Hz.
Pneumatic:	80 - 100 PSI @ 7 CFM.
Finish:	Powder coat
Table height:	23" - 35"

Options:

- Left hand case loading
- 3" tape head
- 60" case magazine
- Stainless steel finish
- Exit conveyors

Case Range:

Length:	8" to 20"
Width:	6" to 15"
Height:	5" to 15"

Right hand layout

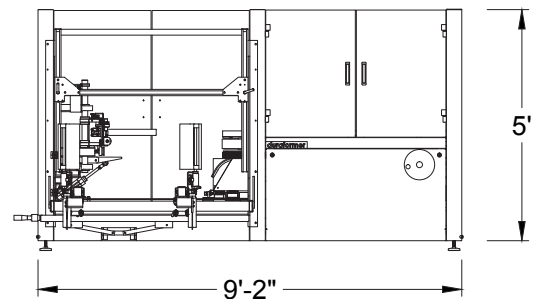
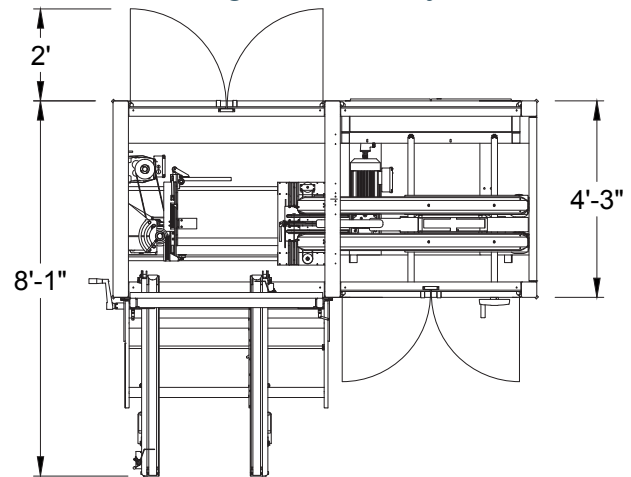

Right hand case orientation

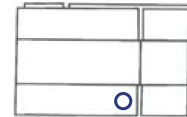

Left hand case orientation

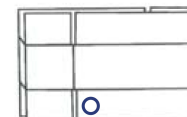

Sam Packaging LLC
5535 W 110th St. Unit 9
Oak Lawn IL, 60453
Tel. (708) 229-7655
Fax (844) 229-7644
www.sampackaging.com
sales@sampackaging.com