

# SP-40

Standard Tape Head

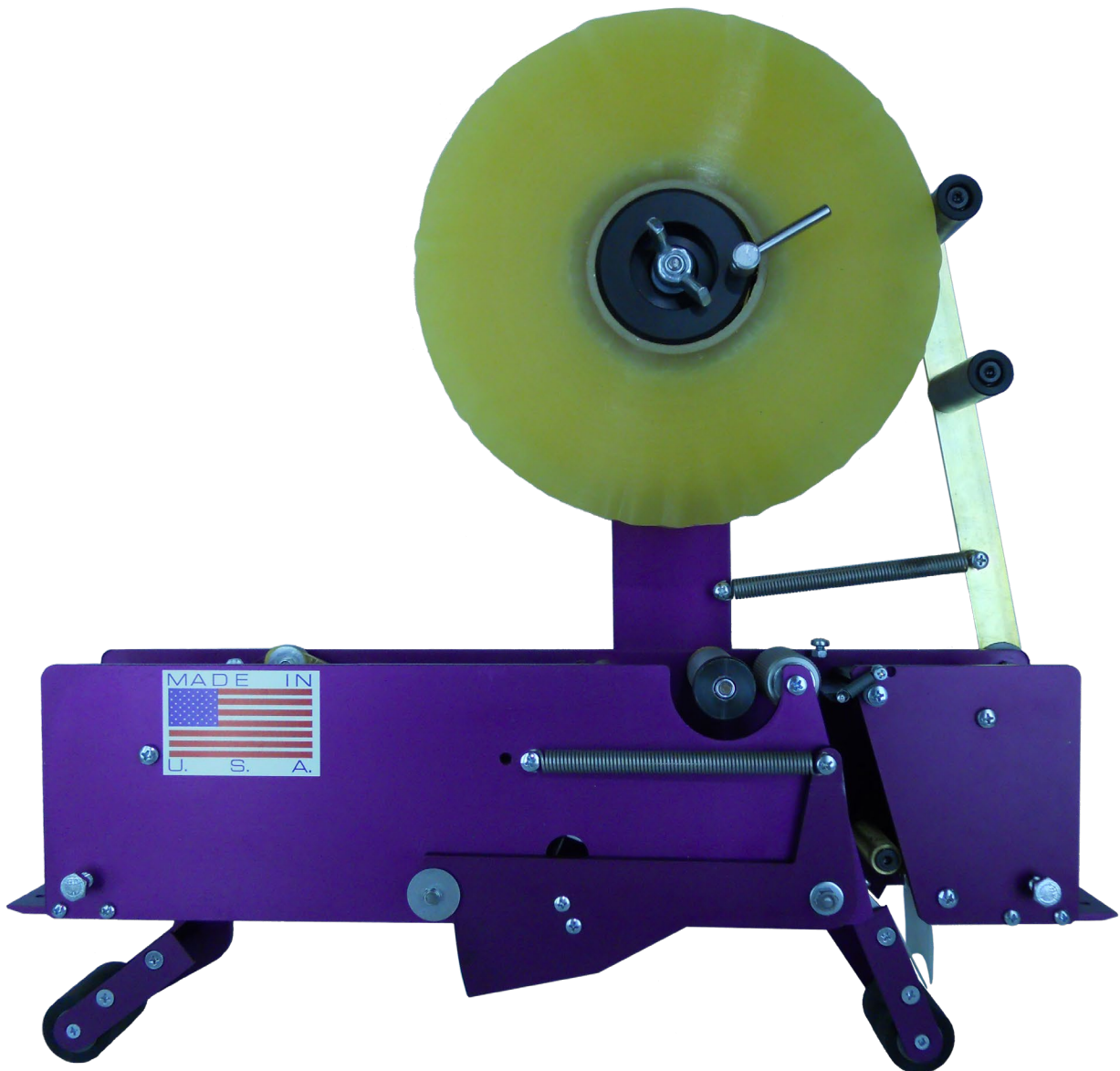

**Sam Packaging LLC**

5535 W 110th St. Unit 9

Oak Lawn IL, 60453

Tel. (708) 229-7655

Fax (844) 229-7644

[www.sampackaging.com](http://www.sampackaging.com)

[sales@sampackaging.com](mailto:sales@sampackaging.com)

# SP-40

Model SP-40 high quality taping heads are designed for both top and bottom installations.

## Features:

- Open tape feed path for easy tape loading
- Lightweight aluminum construction with anodized finish
- Easily exchangeable spring for medium and high speed applications
- Durable, low maintenance design for improved productivity
- Consistent tape application
- Side roller arm for even tape tension
- Long lasting knife blade with extended teeth
- No tools required to change tension
- Works with all brands of tape

## Options:

Model SP-40R	Reverse direction
Model SP-40-3	3" wide tape application
Model SP-40-1.5	1.5" tab length for low boxes

## Technical Specifications:

Speed: 60 to 130 ft/min

Tab length: 2.5" standard

Tape size: 2"

Tape roll: 12"

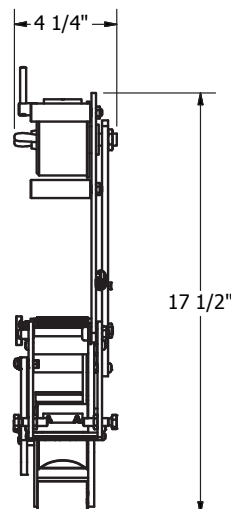
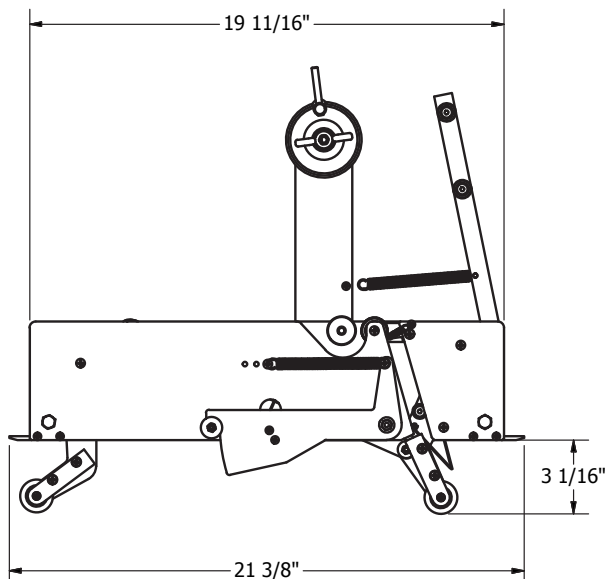

**Sam Packaging LLC**  
5535 W 110th St. Unit 9  
Oak Lawn IL, 60453  
Tel. (708) 229-7655  
Fax (844) 229-7644  
[www.sampackaging.com](http://www.sampackaging.com)  
[sales@sampackaging.com](mailto:sales@sampackaging.com)